

# INSTALLATION/SERVICE MANUAL

FOR

## e-Gate SLD-24V-IND-S

24V Industrial Sliding Gate Operator for Gates to 1000kg

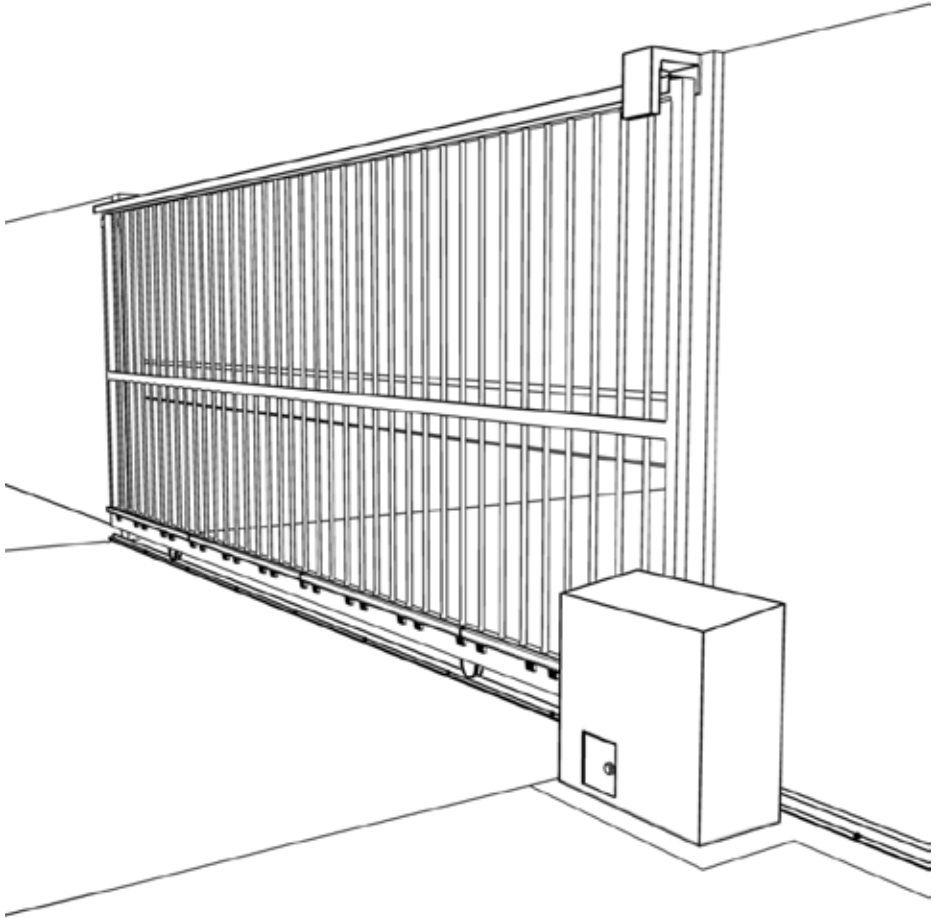

Developers and Manufacturers  
of Gate Automation Technology

# CONTENTS

<b>PRE-INSTALLATION CHECK LIST . . . . .</b>	<b>1</b>
MAXIMUM SIZE OF GATE FOR THE SLD-24V-IND-S . . . . .	1
GATE OPERATOR FREQUENCY OF USE . . . . .	2
ENVIRONMENT SUITABLE FOR THE OPERATOR . . . . .	2
IMPORTANT SAFETY INSTRUCTIONS! . . . . .	3
TOOLS AND HARDWARE REQUIRED . . . . .	4
PREPARING THE GATE . . . . .	5
GUIDE POST CLEARANCE . . . . .	5
AUTOMATIC OPERATOR FITTING REQUIREMENTS . . . . .	6
ACCESSORIES THAT CAN BE ADDED . . . . .	7
SAFETY PHOTOCELL . . . . .	7
DIGITAL KEYPAD AND/OR INTERCOM . . . . .	8
A GROUND LOOP VEHICLE DETECTOR . . . . .	8
<b>CABLING REQUIREMENTS . . . . .</b>	<b>9</b>
BASIC CABLING GUIDE . . . . .	9
FULL CABLING GUIDE . . . . .	9
TYPE AND SIZE OF CABLE . . . . .	10
<b>HOW IT WORKS . . . . .</b>	<b>11</b>

# 8 STEPS TO INSTALLING THE SLD-24V-IND-S . . . 12

<b>STEP 1 - INSTALL CABLING</b> . . . . .	<b>12</b>
TIPS FOR RUNNING LOW VOLTAGE CABLE YOURSELF.	13
<b>STEP 2 - FIT THE OPERATOR</b> . . . . .	<b>13</b>
POSITION OF THE OPERATOR	13
FIX THE OPERATOR IN PLACE	14
MANUALLY RELEASE THE OPERATOR	14
<b>STEP 3 - FIT THE RACK TO THE GATE</b> . . . . .	<b>15</b>
<b>STEP 4 - TERMINATE CABLING</b> . . . . .	<b>19</b>
SLD-24V-S GENERAL WIRING DIAGRAM	19
CHECKING THE GATE DIRECTION	20
TERMINATING A PHOTOCCELL	21
TERMINATING A LIGHT	21
TERMINATING DIGITAL KEYPAD, CARD ACCESS, KEY SWITCH OR PRESS BUTTON	22
TERMINATING GROUND LOOP VEHICLE DETECTOR	22
TERMINATING A 7-DAY TIMER, DIGITAL KEYPAD OR KEYSWITCH	23
TERMINATING AN INTERCOM	23
TERMINATING SEPERATE OPEN, STOP AND CLOSE P/B'S	24
TERMINATING EMERGENCE STOP DEVICES	24
<b>STEP 5 - TUNE THE REMOTE CONTROLS IN</b> . . . . .	<b>25</b>
REMOTE CONTROL OPEN, STOP AND MANUAL CLOSE	25
REMOTE CONTROL OPEN WITH AUTO-CLOSE	25
REMOVING REMOTE CONTROLS	26
REMOTE CONTROLLED PEDESTRIAN ENTRY	26
USER ADDING REMOTE CONTROL AT A LATER DATE	26
<b>STEP 6 - LEARN GATE OPEN LIMIT</b> . . . . .	<b>27</b>
<b>STEP 7 - ACTIVATE AND TEST ACCESSORIES</b> . . . . .	<b>28</b>
OTHER OPTIONS FOR CONTROL INPUTS	28
<b>STEP8 - FINE TUNE GATE OPERATOR PREFERENCES</b> . . . . .	<b>29</b>
CHANGING THE AUTO-CLOSE DELAY	29
CHANGING THE PHOTOCCELL-CLOSE DELAY	29
CHANGING THE PEDESTRIAN-CLOSE DELAY	30
CHANGING UP THE LOCK/LIGHT OUTPUT	30
CHANGING THE LEVEL OF SOFT START AND SOFT STOP	31
CHANGING THE GATE OBSTRUCTION SENSITIVITY	31
<b>RETURN TO FACTORY SETTINGS</b> . . . . .	<b>32</b>
<b>RECOMMENDED MAINTENANCE SCHEDULE</b> . . . . .	<b>33</b>
<b>MAINTENANCE CHECK LIST</b> . . . . .	<b>34</b>
<b>MAINTENANCE HISTORY</b> . . . . .	<b>34</b>
<b>ACCESSORIES AVAILABLE</b> . . . . .	<b>35</b>
<b>TROUBLE SHOOTING</b> . . . . .	<b>35</b>
<b>WARRANTY</b> . . . . .	<b>36</b>

# PRE-INSTALLATION CHECK LIST

## MAXIMUM SIZE OF GATE FOR THE SLD-24V-IND-S

If this Gate Operator is installed on a gate that is too Heavy it may not work properly.

### Aluminium Gates with Open Bar Cladding or Pipe and Chain Link

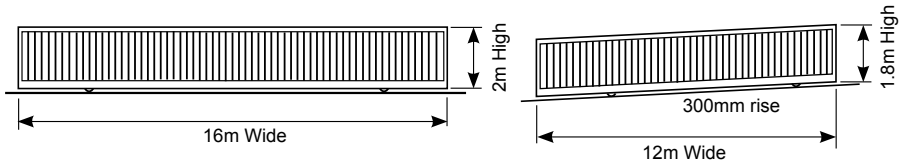

### Aluminium Gates with Aluminium or Timber Slats or Steel Gates with Open Bars

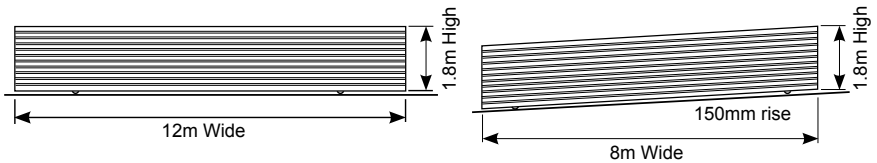

### Steel Gates with Hardwood Slats or Solid Hardwood gates

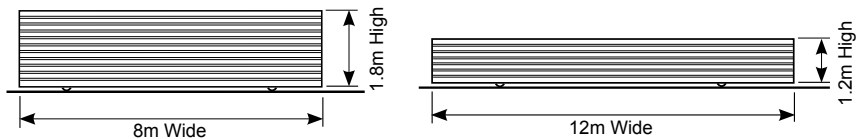

## **GATE OPERATOR FREQUENCY OF USE**

This Gate Operator is rated for **INDUSTRIAL** use, which is any Housing Estates, Commercial or Industrial Building Car Parks or Entry ways that have anything up to continuous use.

### **Gate Open During Power Failure System**

This operator runs off a 24V 7Ah battery and uses a Power drop out relay so if the power fails the gate will open and remain open until the power is restored. With a full set of accessories and a magnetic clamp connected the battery will last up to 10 hours and still operate normally when power restored. If power is likely to off for longer than 10 hours then a larger battery may be installed. Adding a second set of 7Ah batteries will give 35hours standby time and adding a 26Ah battery will give up 100 hours standby time.

### **Gate Continues to Operate During Power Failure System**

The standard battery will give up to 6 hours continuous operation at 60 operations per hour for an averaged sized gate, less for a heavier gate. If a 26Ah battery is added this will be extended this to 16 hours or a 65Ah Battery will extend this to 36hours.

If the battery is allowed to run flat then once power is restored the operator will work normally straight away and charge the battery automatically, but the battery will require some time to charge fully.

### **Solar Powered Systems**

Are generally not recommended for Industrial Gate Operators because the accessories draw a lot more power than a residential operator.

If mains power is out of the question then a suitable solar system will need to be engineered specifically for the climate and usage for Industrial Gate Operators. Wind turbines are also a good alternate to Solar in some area's. Contact your local dealer for more information.

## **ENVIRONMENT SUITABLE FOR OPERATOR**

The SWG-24V-IND-S is suitable for outdoor use so long as it is NOT exposed for long periods to salty air or other corrosive substance or contaminants that may cause fouling of the gate, gate operator, any of the gate operators components or accessores that may be connected to the operator.

# **IMPORTANT SAFETY INSTRUCTIONS!**

## **CONSIDERING THE GENERAL PUBLIC:**

When Installing an Automatic Gate that will be entered from a public road way, make sure the Gate is placed far enough from the road to prevent traffic congestion.

The Gate must be installed in a location that provides adequate clearance between it and adjacent structures when opening and closing to reduce risk of entrapment. **Swing gates must not open into public access areas!**

Install the Gate Operator on the inside of the property and fence line. **DO NOT** install an opener on the outside of the gate where the public has access to it.

The Gate and Gate Operator must comply with any applicable local council regulations.

## **CONSIDERING THE USERS:**

Industrial Gate Operators must use Point to Point Safety Photocells to help prevent the gate closing on any vehicle using the gate.

It is also recommended that a separate small side gate is used for pedestrians particularly if there will be children, disabled or elderly people using the gate.

If push buttons, key switches or Digital Keypads are installed, they should be within sight of the gate but not placed so the user will be tempted to reach through the gate to activate the gate operator.

## **USER AWARENESS:**

It is important to make sure everyone that will be using the gate is aware of the following dangers associated with automatic Gates: do not contact any part of the gate or walk in the path of the gate while it is moving. Never let children play with the gate controls. Do not attempt to "beat the gate" while it is closing. This is extremely dangerous.

In the event you sell the property, make sure the new owners have a copy of these instructions. If you lose the instructions they can be downloaded from: [www.grantsautomation.com.au](http://www.grantsautomation.com.au).

## **TOOLS AND HARDWARE REQUIRED**

### **THE TOOLS YOU'LL NEED INCLUDE:**

A basic set of hand tools will be needed including: side cutters, pliers, wire strippers, a range of phillips head screw drivers, a small flat head screw driver for terminal block screws and a socket set.

You'll also need a tape measure, marking pen, an electric drill with hammer action and variable speed control, a 10mm hammer drill bit and socket bit for 10mm or 3/8" tek screws. An angle grinder is also handy although a hacksaw will do if you don't have one.

If you intend on doing your own low voltage cabling a pair of conduit cutters are handy although a hacksaw can also be used. If you wish to run cabling across the driveway you will need either a 230mm angle grinder with masonry grinding disc or a hand held concrete cutter. You can hire these if necessary. If you'll be running cabling across a lawn or garden you'll need a spade and mattock for digging a low trench. If it's a long run then a small trench digger can be hired to do the job.

### **YOU MAY ALSO NEED THESE ITEMS BEFORE INSTALLATION**

For systems with accessories added **Low Voltage Cable is required** see "Cabling Requirements" for more information.

**You may also need conduit, which is available from Electrical trade suppliers and hardware stores.**

For Mains Powered Systems you will need a mains power point mounted on a free standing post in front of the gate next to automatic operator. Check with local regulations before installing a mains voltage power point yourself, you may need a registered electrician to do this for you.

## PREPARING THE GATE

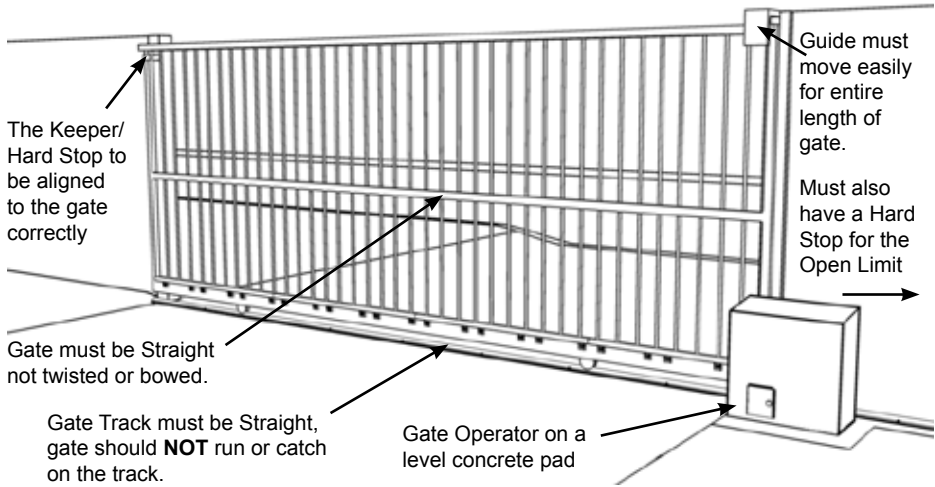

Make sure that the gate has been properly installed, is straight and slides freely throughout its entire length without any grabbing from the guides or track anywhere along the gate. The **GATE TRACK MUST BE IN A STRAIGHT LINE** any sudden dips or rises may prevent the gate operator from being installed properly. Repair or replace all worn or damaged gate hardware prior to installation. Gate posts less than 150mm wide should be made from steel not timber. Replace posts where necessary. A freely moving gate will require less force to operate and will enhance the performance of the operator and give a long working life.

The operator should be well drained and not be submersed in water or have water running past it in heavy rain.

## GUIDE POST CLEARANCE

If using a guide post behind a gate allow at least 60mm clearance for the Rack. If the guide is fitted to the front Fence or Wall the clearance has no effect so long as the Gate does not contact it at all.

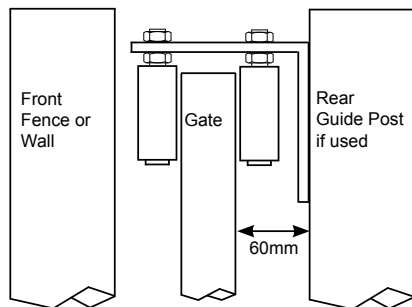



## ACCESSORIES THAT CAN BE ADDED

### SAFETY PHOTOCELL

Photocells are a safety device that prevent the gate from closing on a vehicle. They are **COMPULSARY WITH INDUSTRIAL GATES**

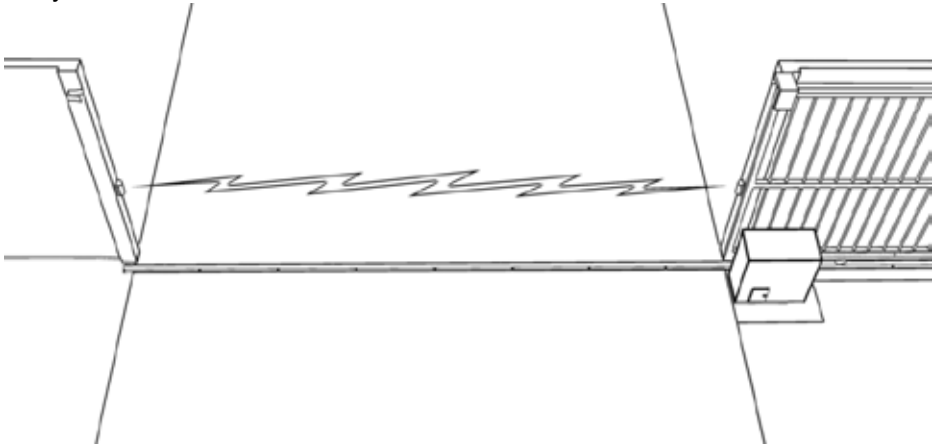

A Photocell consists of an Invisible Low Power Infrared point to point Beam Transmitted from one side of a gate to the other. **REFLECTOR TYPES** are **NOT** recommended for outdoors.

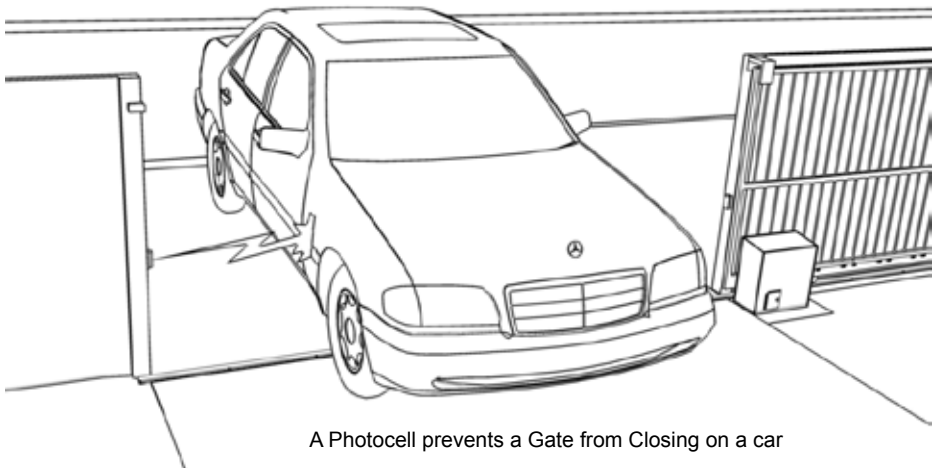

A Photocell prevents a Gate from Closing on a car

If the Photocell's beam is interrupted by a vehicle, the gate won't close. The Photocell can also be used to control the closing of the gate.

## DIGITAL KEYPAD, CARD ACCESS AND/OR INTERCOM

To allow access to visitors or tradesman any brand of digital keypad, Card Access system and/or intercom can be installed (provided the intercom has a door release feature).

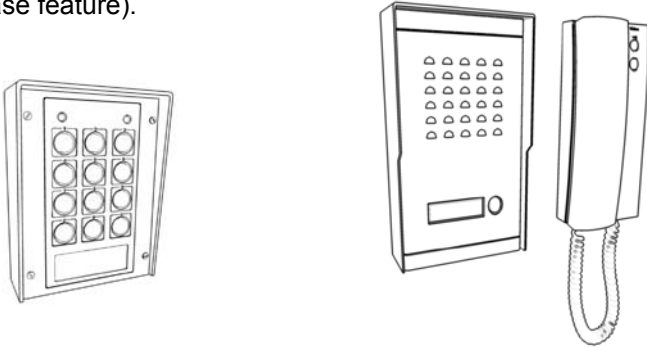

A Digital Keypad or Proximity Card System allows access to anyone with the correct pin number or card.

An Intercom allows visitors to call the house and speak with the occupier. If the occupier wishes to let the visitor in they can press a button on the intercom inside to open the gate.

## A GROUND LOOP VEHICLE DETECTOR

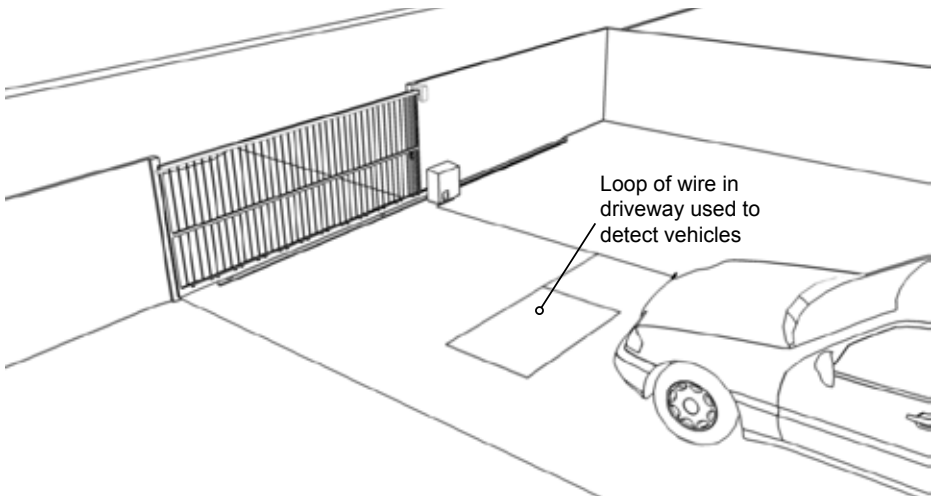

A ground loop in the driveway detects any vehicles approaching the gate and opens it automatically to let them out. Pedestrians cannot use the ground loop to open the gate, which is a safe guard from anyone jumping the fence.

# CABLING REQUIREMENTS

## BASIC CABLING GUIDE

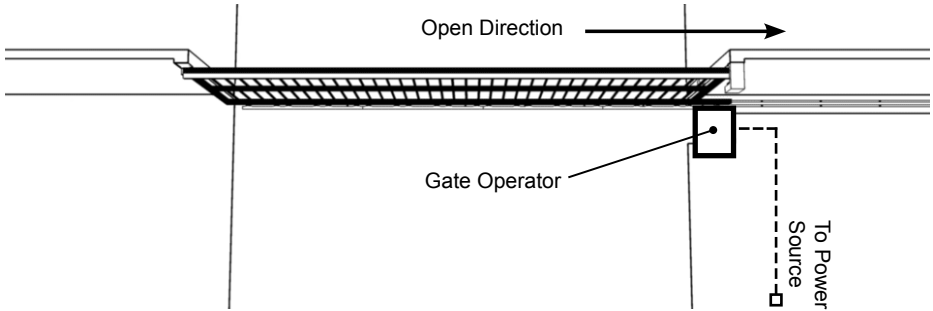

## FULL CABLING GUIDE RIGHT HAND GATE

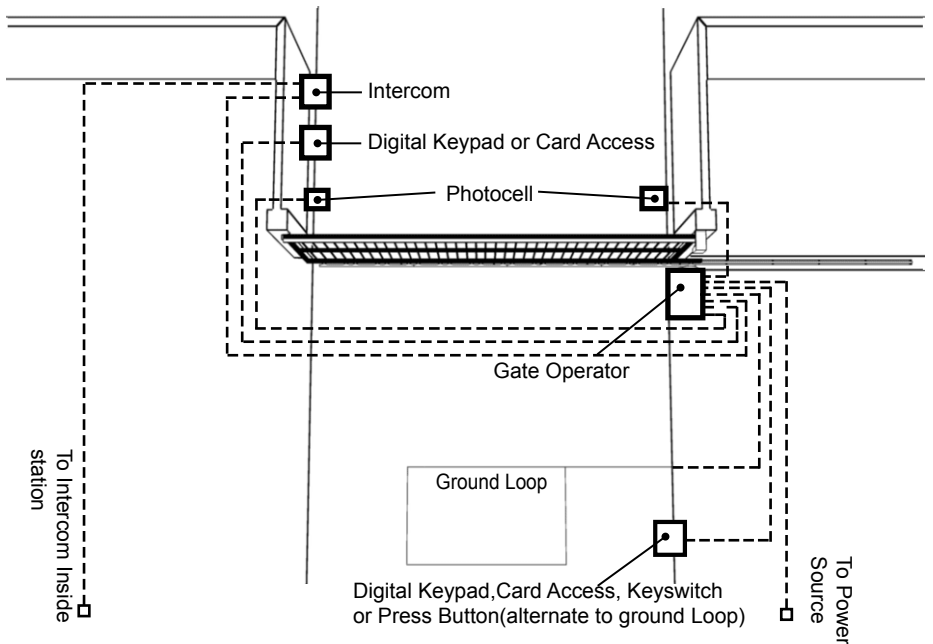

For a gate sliding from the left side the Operator and Power cable will be on the opposite side. Cable for the electric lock may run in the gate frame. The 240VAC Mains should be kept at least 100mm away from any low voltage cabling.

## TYPE AND SIZE OF CABLE

Power is supplied either by an Outdoor Power point fitted near the operator on one side only or hard wired. Check with local regulations before installing any mains voltage wiring yourself, you may need a registered electrician to do this for you. ***DO NOT pull the charge unit out and run full 24VDC power out to the gate as the voltage drop will prevent batteries charging properly!***

For low voltage cabling the following cable size and type is recommended:

### **For Accessories**

0.4mm Diameter (0.12mm<sup>2</sup>) or 0.65mm Diameter (0.33mm<sup>2</sup>) Outdoor telephone cable is ideal for Connecting Photocells, Digital Keypads and Intercoms as this cable has a tough outer sheath and is gel filled to protect it from moisture. Cat 5e and indoor phone cable is fine to use so long as it isn't exposed to moisture for prolonged periods. If using security cable this must be a conduit that is fully sealed to prevent any exposure to moisture.

## HOW IT WORKS

The SLD-24V-IND-S Gate Operator consists of an electro-mechanical drive unit with built in electronic controls that connects with racking on the gate driving it open or closed.

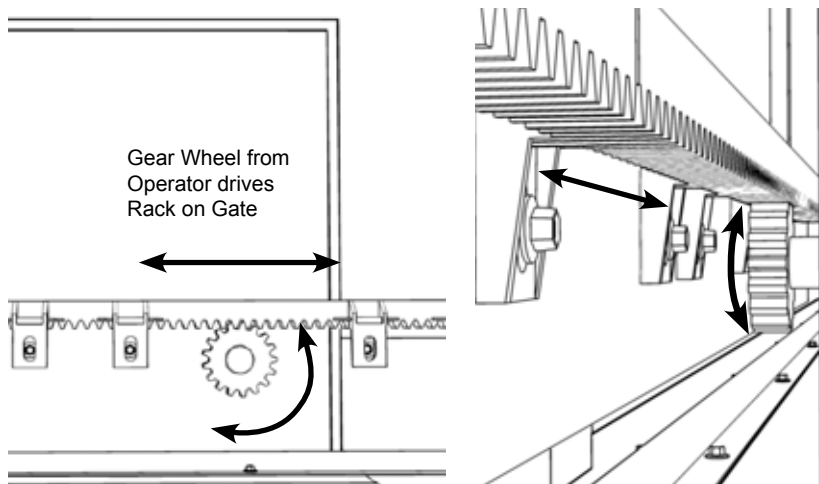

When the Operator is activated by remote control or other control device, it drives the gate open or closed. A toothed rack is fitted to the gate that engages with an output Gear Wheel on the operator. Hard stops are used to determine the open and close limits of the gate. The electronic controls also continually monitor the loading on the gate when ever it is operating so if the gate is obstructed it will reverse direction for safety.

Limit switches with are NOT used with Industrial sliding gate operators as the strike plate on the Rack is a target for Vandals and Limit Switches that work within the operator can get out if the gate jumps a cog. This operator ramps the speed down for a soft stop and applies a light pressure to the hard stop.

The operator has an electric brake to prevent the gate being forced open.

# 8 STEPS TO INSTALLING THE SLD-24V-IND-S

## STEP 1 - INSTALL CABLING

Check with local regulations before installing mains voltage yourself, you may need a registered electrician to do this for you. Normally any cable for voltage lower than 32VAC or 50VDC you can do your self without a license.

If your gate track is hollow you can run low voltage cabling through this. If it isn't and you need to run Low Voltage Cable across a concrete or bitumen driveway or path you can do this by chasing a groove with a 9" angle grinder with a masonry grinding disc (not a cutting disc). Make it deep enough so there is 5mm or so space above the cable when installed. Use an expansion gap where possible as this requires less work. Make sure the cable will not be pinched if between two slabs of concrete that can shift with ground movement.

Fix the cable into the groove using clear plumbers silicon (non acidic) or other flexible sealer in the clean groove before the cable and again after, making sure it sticks to both sides of the groove. If the path or driveway has lawn or garden edges make sure the cable isn't exposed or accessible to edge trimmers or spades by running the groove down the edge and into conduit just under the edge of the driveway. You'll need to dig a hole next to the driveway to do this.

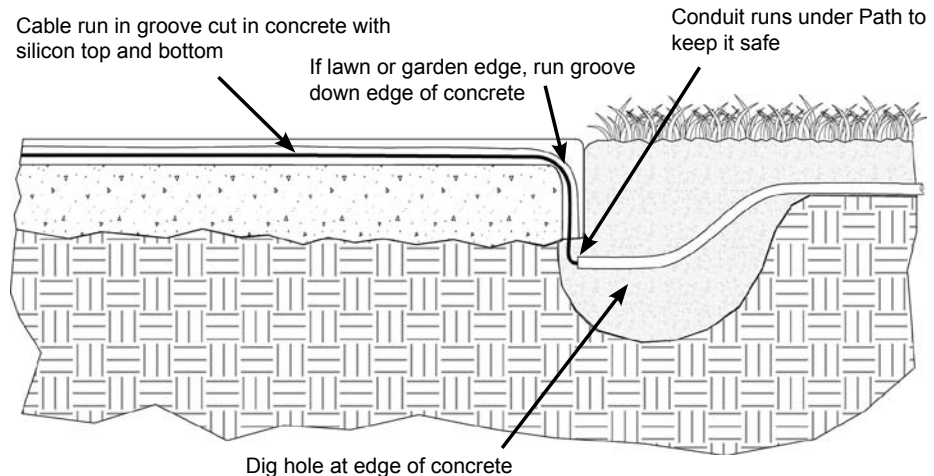

If the driveway meets a post and you need to go around it then chase a groove where you can with the angle grinder then use a rotary hammer drill as a mini jack hammer for the corners and fiddly bits.

## TIPS FOR RUNNING LOW VOLTAGE CABLE YOURSELF.

- ⚡ Always use conduit if running cable in grass, open ground, gardens or pebbles.
- ⚡ Conduit should be buried deep enough so it is out of harms way. For existing lawns, pebbled areas or if run along side a driveway then buried just below the surface is fine. For open ground, gardens and area's where there is likely to be other digging going on then conduit should be buried at least 300mm deep.
- ⚡ Never make joints in cable directly in the ground. If you must join cable, either bring it up well above the ground and have the joint protected from the elements by a weather proof junction box or put a pit in the ground to make sure the joint is sitting in the air within the pit and cannot be submerged in water.

## STEP 2 - FIT THE OPERATOR

### POSITION OF THE OPERATOR

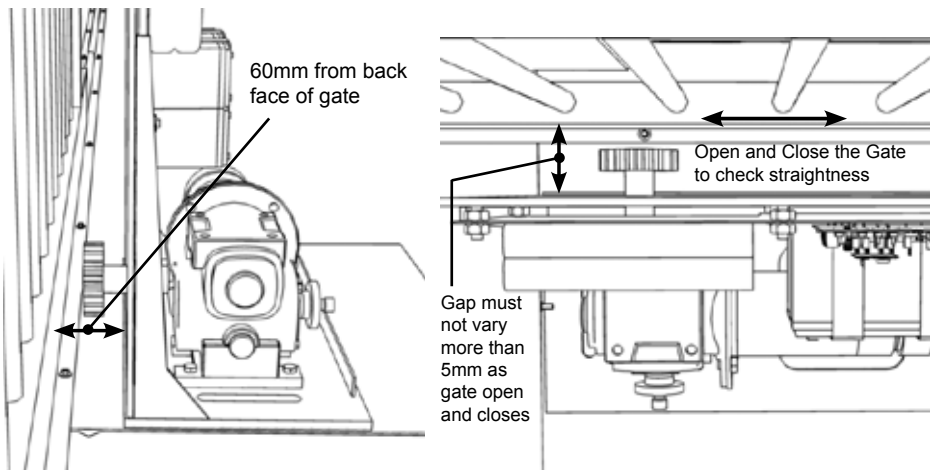

Remove the Cover of the Operator then place it on it's concrete pad 60mm from the back face of the gate. Then open and close the gate checking this distance from the operator as you go. It should not vary more than 5mm each way from fully open to fully closed other wise the gate and/or track is not straight enough and the gear wheel may not contact the rack well enough.

## FIX THE OPERATOR IN PLACE

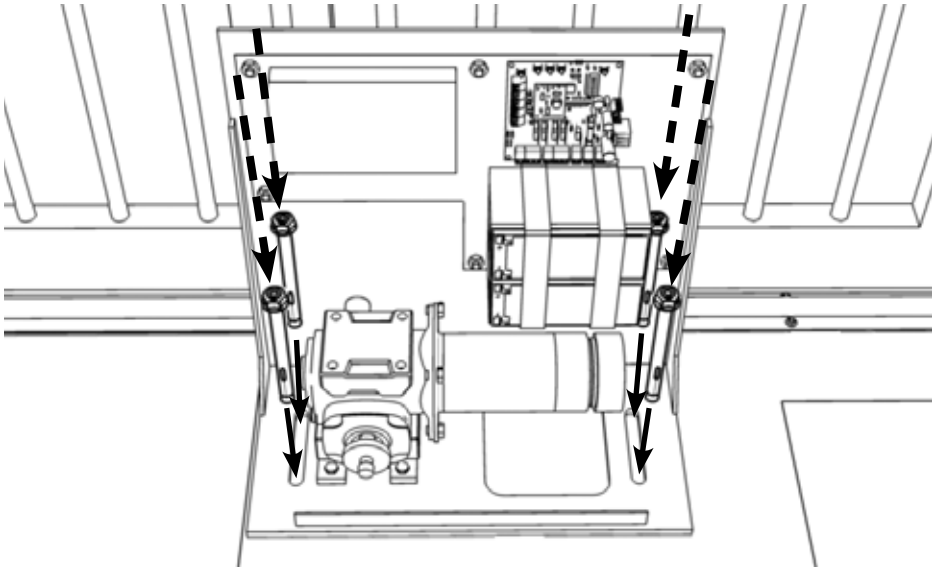

Fix the Operator to it's Concrete Pad using M10 x 50mm Dyna bolts or longer if necessary. Use galvanised Dyna bolts if you can so they won't rust. Large raw plugs and galvanised screws may also be used if preferred. The important thing is, once the Operator is fitted, it doesn't move.

## MANUALLY RELEASE THE OPERATOR

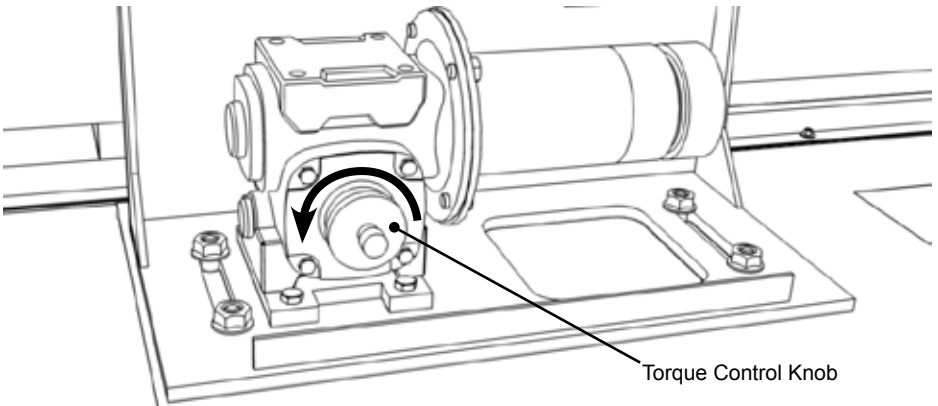

To manually release the Operator loosen the knurled torque control knob on the gearbox until the Operators Gear Wheel will turn freely. To re-engage, re-tighten the knurled torque control knob. If the cover is ON this knob can be accessed through a small locked door using the key is provided.

### STEP 3 - FIT THE RACK TO THE GATE

Before fitting any rack, lay it out in front of the closed gate to see how it lines up. Start at the operator end, with the first length sitting on the operators gear wheel, adjusting the position of the rack as you go to make sure the mounting lugs miss the wheels. If the last length needs to be cut shorter, it must have at least two mounting lugs attached to the gate.

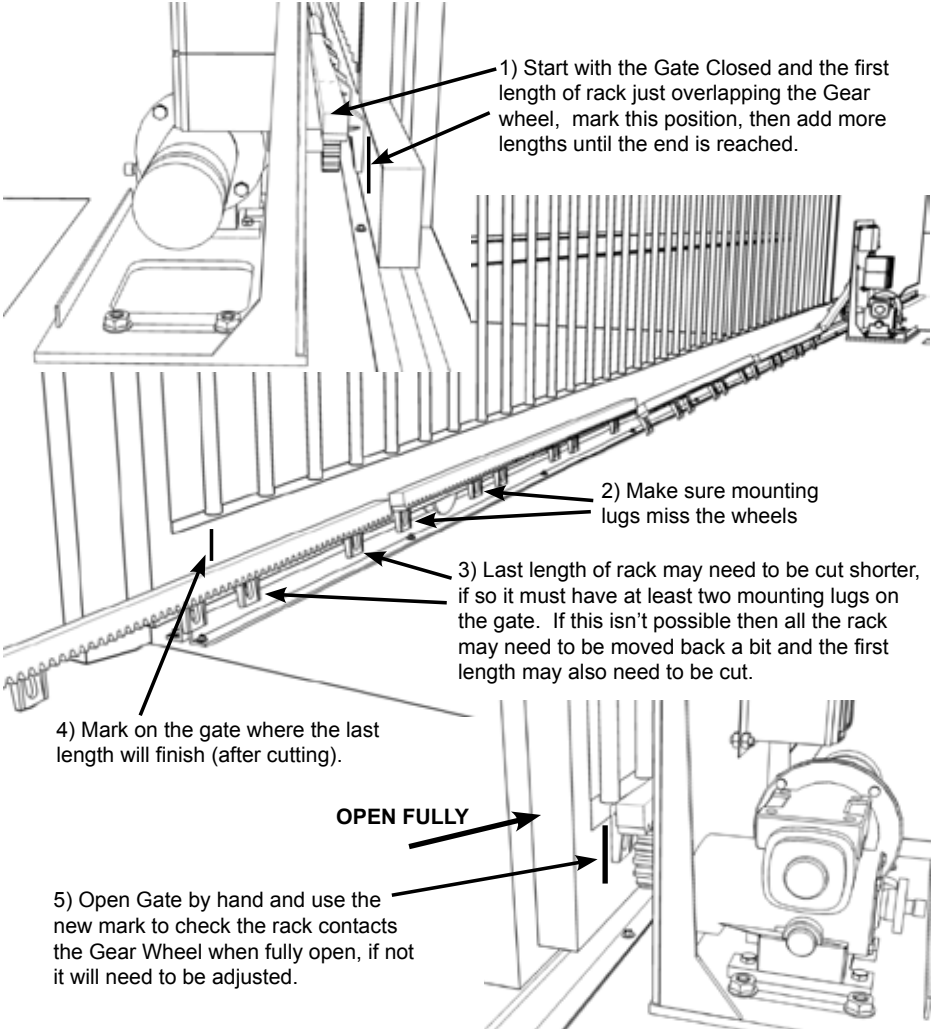

This gate operator has no limit switch strike plates or magnet on the rack so the rack need only overlap the gear wheel by a small amount.

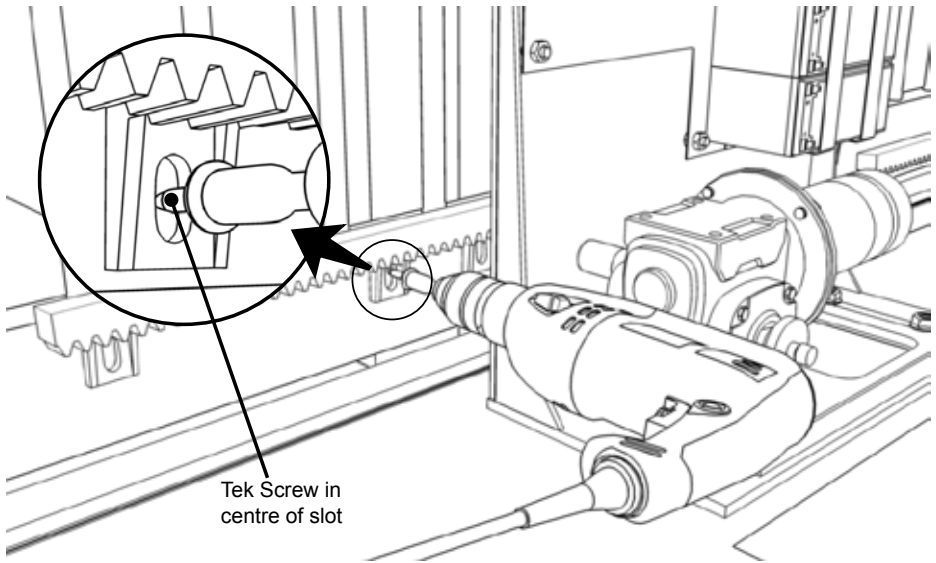

To fit the Rack, start with the gate nearly closed and place the first length of rack on the Operators Gear Wheel, in line with the mark you made earlier and the bottom rail. Drill two 10mm (or 3/8") Tek screws into mounting lugs for the rack, making sure they are both in the centre of each slot. Use only two and do not fully tighten at this stage, as the height of the rack needs to be adjusted.

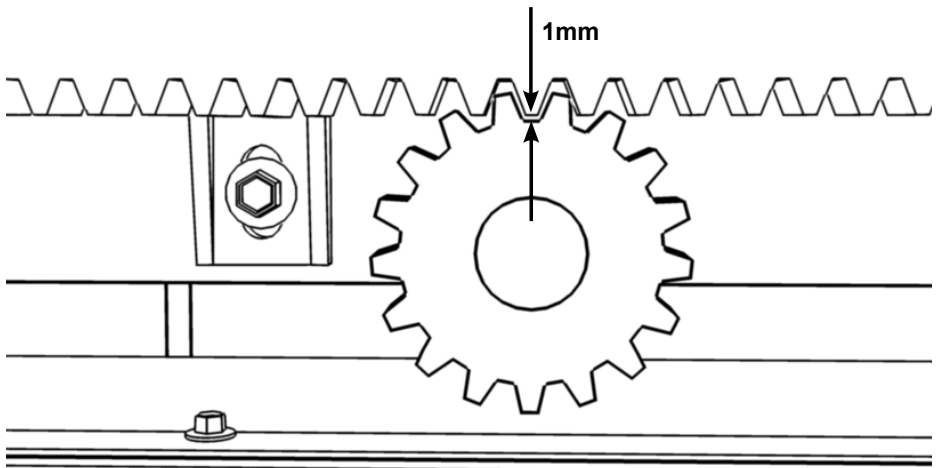

Move the gate by hand until each of the Tek screws are aligned with the gear wheel and adjust the height of the rack until it has about 1mm clearance above the gear wheel. Tighten the tek screws fully once the height is correct.

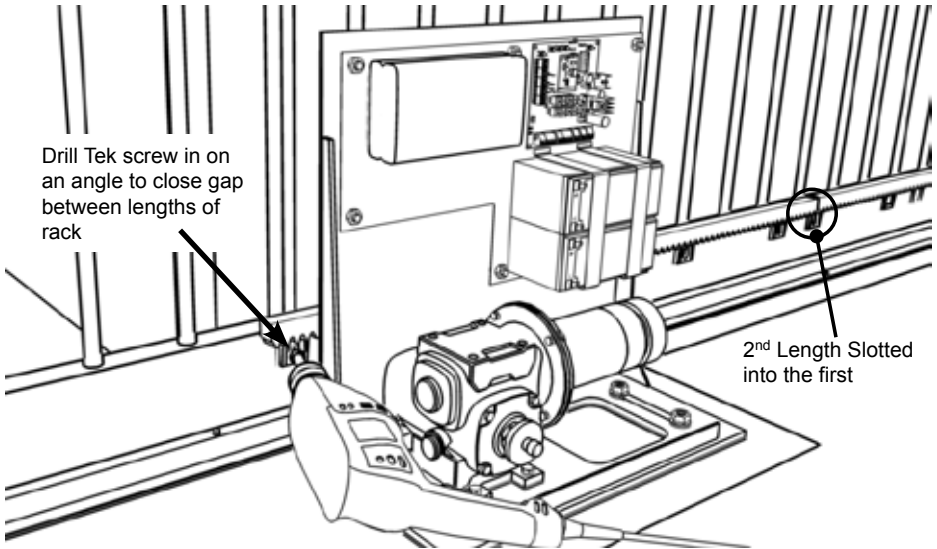

Now fit the 2<sup>nd</sup> length of rack by sliding the gate open a bit further and placing it so one end is slotted into the first length and the other end is sitting on the operators gear wheel, allowing enough room to drill another tek screw in. Drill the tek screw in on an angle to close up any gap between the two lengths.

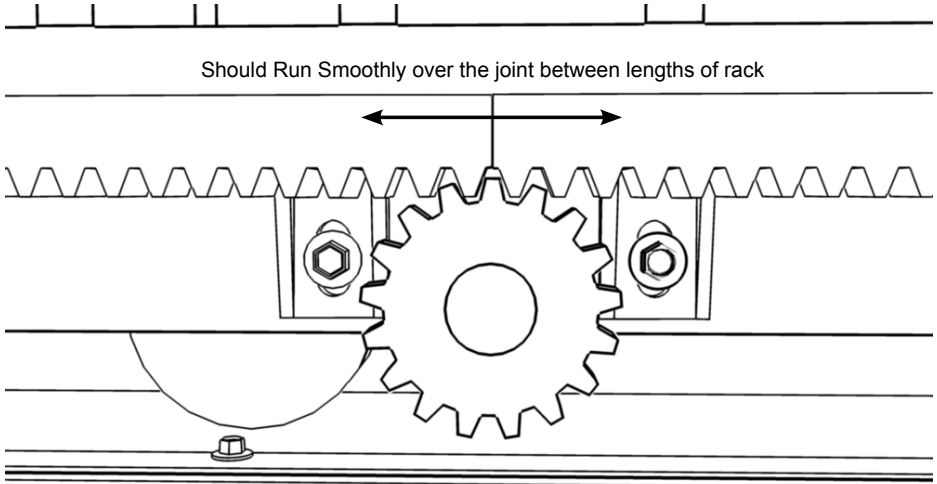

If the gate is now moved by hand and run over the joint between the lengths of rack, there should be no jump, it should run smoothly over the joint. Also set the 1mm clearance at the new tek screw position and tighten it up fully. Repeat the same with the remaining lengths of rack, just tacking them all in place for now with two tek screws.

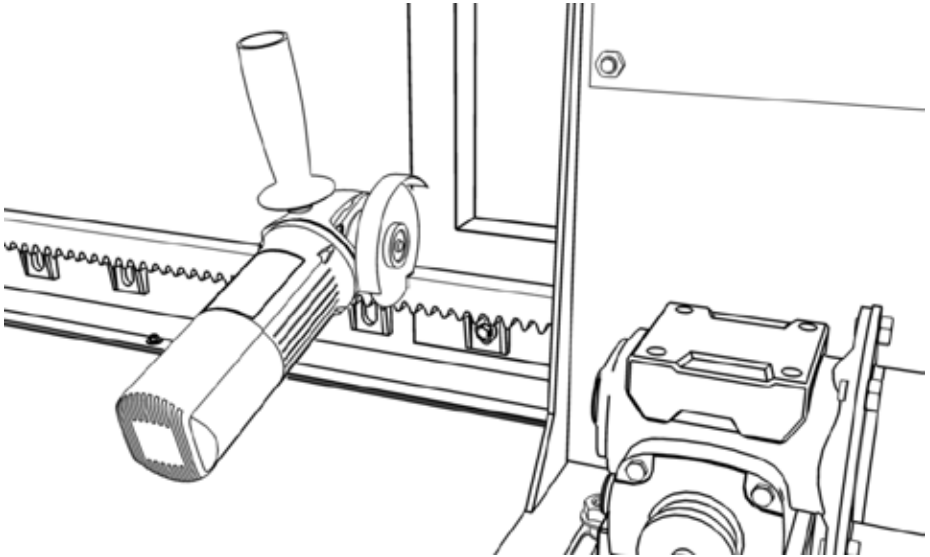

Once all lengths are tacked in place and the gate is opened and closed to check the rack contacts the gear wheel at all times then cut off any excess rack using an angle grinder or hack saw. The Rack may be plastic on the outside but it has a steel rod in the middle.

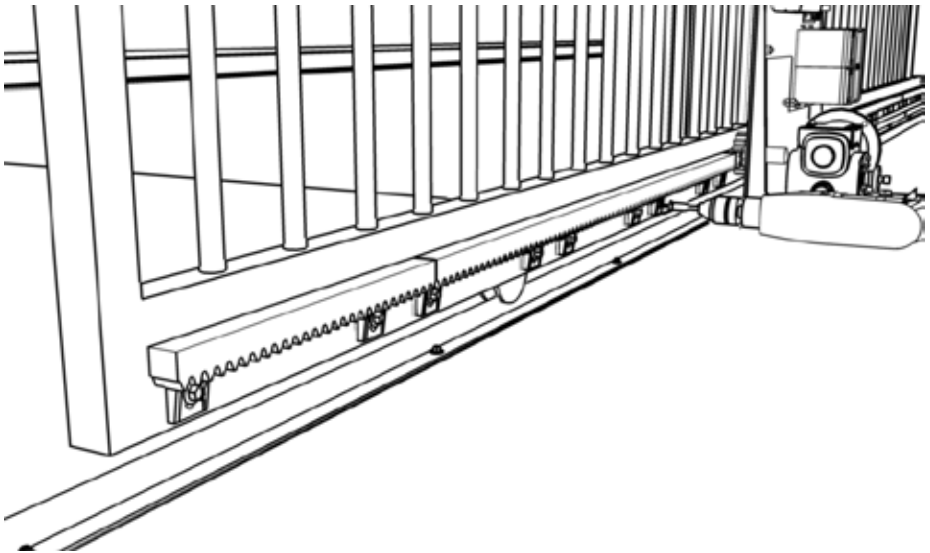

Now go through and tek screw **ALL MOUNTING LUGS** for the rack that haven't been done yet, adjusting the 1mm clearance from the gear wheel as you go. It is quicker to do these all in one run.

# STEP 4 - TERMINATE CABLING

## SLD-24V-IND-S GENERAL WIRING DIAGRAM

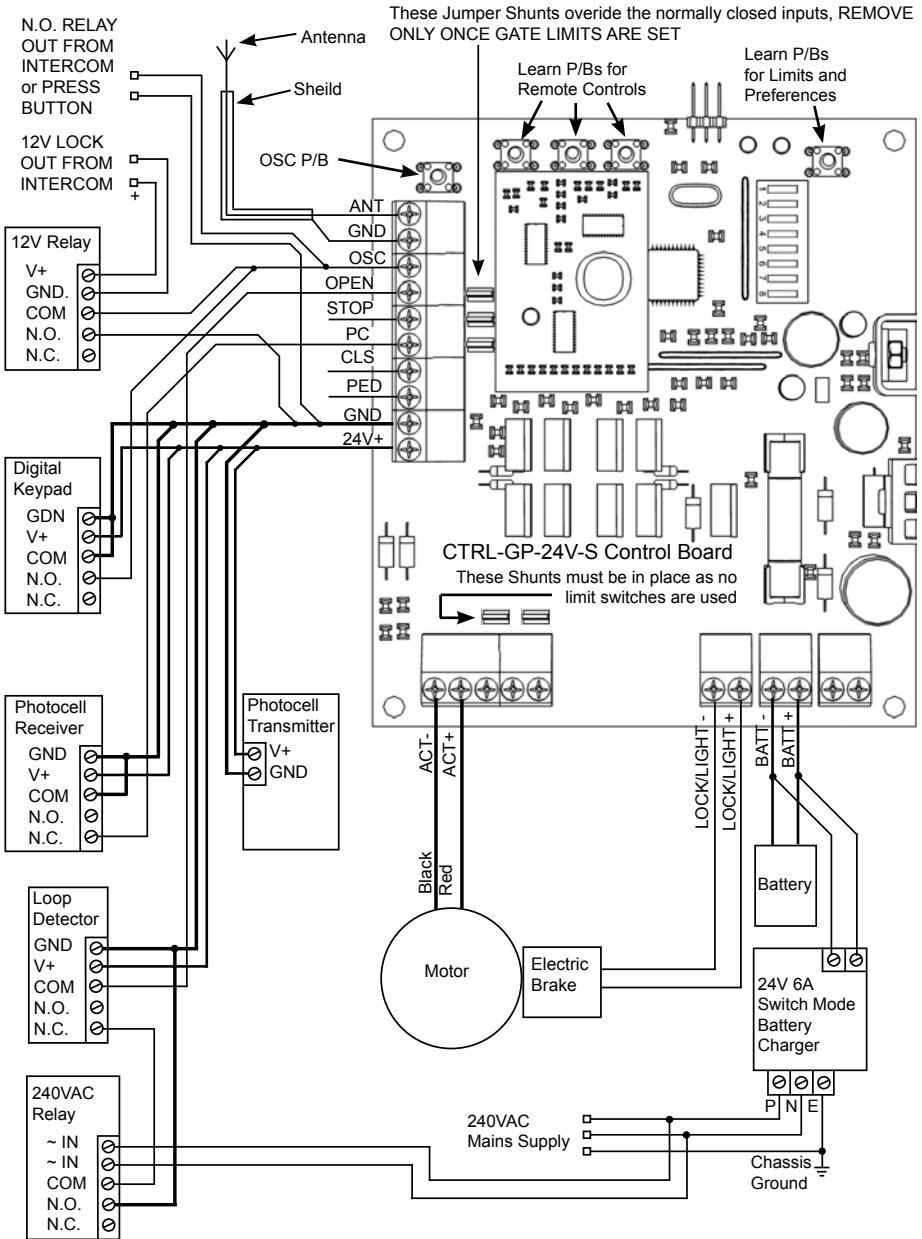

Power Drop Out Relay for Gate open during Power Failure option only

## CHECKING THE GATE DIRECTION

The Gate Operator is prewired for a Left Hand Gate.

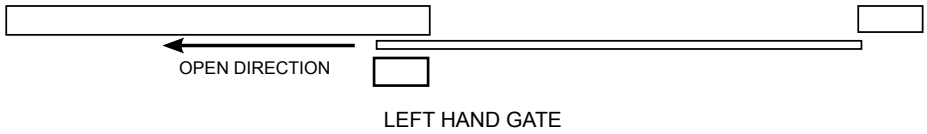

If you have a Right Hand Gate then you'll need to change the Motor Power wires around.

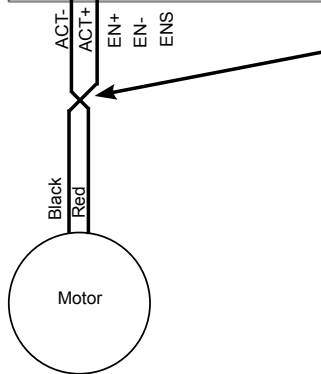
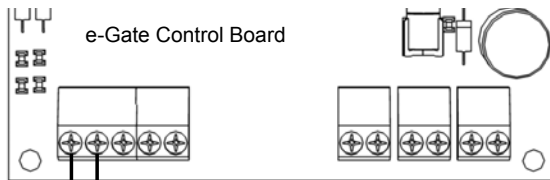
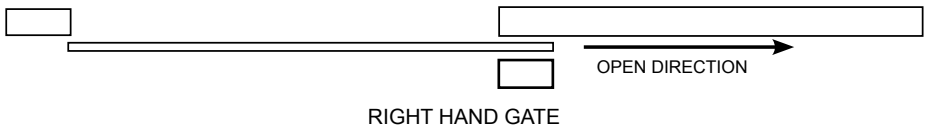

For Right Hand Gates change the Red and Black Motor Power wires around so the gate will travel in the opposite direction.

The terminal blocks on the control board unplug to allow easier and better connections.

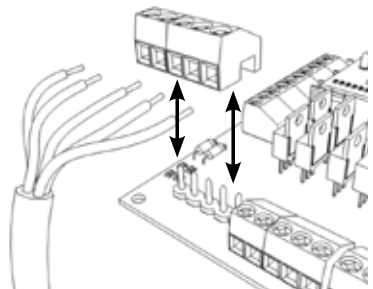

Make sure all strands of the wire are tightly held by the terminal block. Stray strands can cause a short circuit.

## TERMINATING A PHOTOCELL

Safety Photocells use a 'normally closed' connection to the control board. If the photocells light beam is broken by a vehicle while the gate is closing it will be reversed back open again. The gate will not close until the photocell light beam is remade and vehicle is clear. If a photocell closing delay option is activated (DIP 3 ON) the gate will begin to close once the photocell close delay has timed out rather than the auto-close delay.

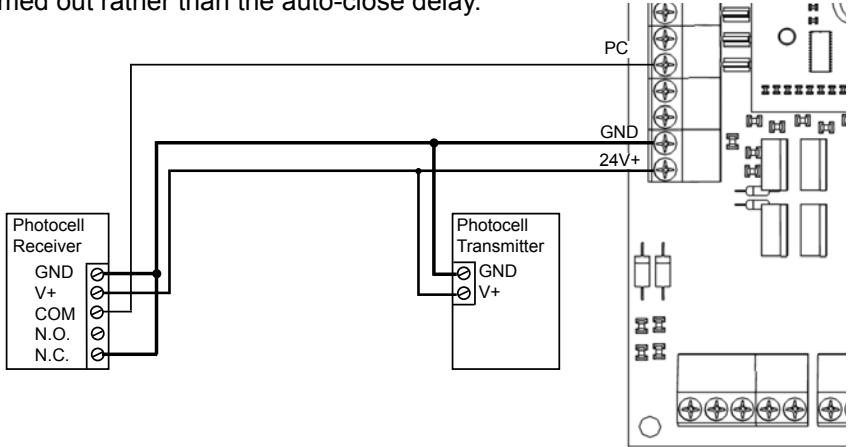

## TERMINATING A LIGHT

By connecting a 24VDC relay to the gate operator it can also activate lights for 1 or 4 minutes when ever the gate is opened. See "Changing the LOCK/LIGHT output" section in Step 8 for information on how to change this.

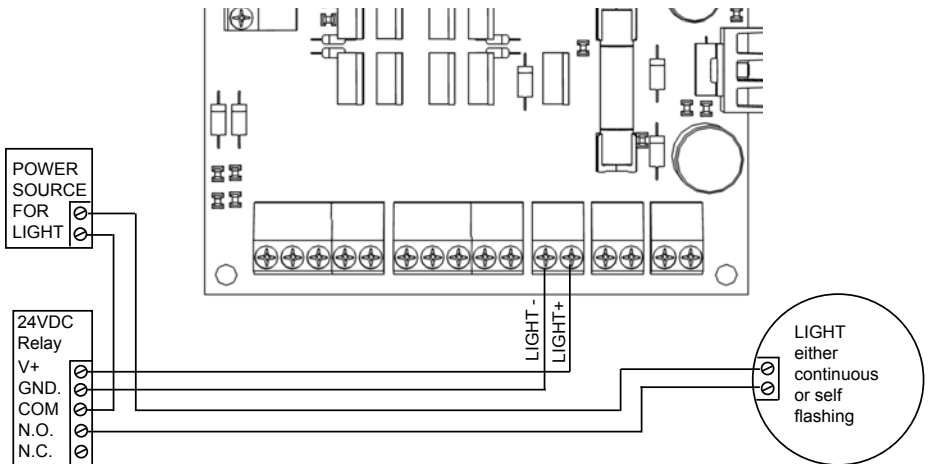

## TERMINATING DIGITAL KEYPAD, CARD ACCESS, KEY SWITCH OR PRESS BUTTON

A Digital Keypad, Card Access System, Key switch, Press Button or any other clean contact normally Open (NO) device can be used to activate the gate. If a Digital keypad has two or more relay outputs, then these can be used for different operational functions such as open with manual close, open with auto-close or Pedestrian only access with auto-close.

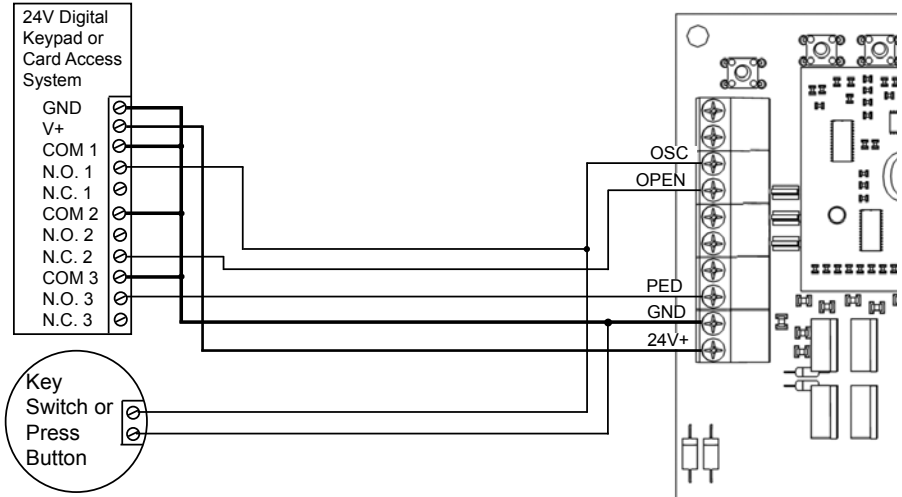

## TERMINATING GROUND LOOP VEHICLE DETECTOR

A ground loop must be used with a photocell to control the opening and closing of a gate. If a vehicle wishing to exit drives over the ground loop the gate will open. If the vehicle remains over the ground loop or the photocell light beam is broken the gate will remain open. Once both are clear the gate will auto-close normally or if the photocell closing control is active (DIP 3 ON), will close immediately or can be delayed. For incoming vehicles sharing the same gate the photocells closing control is inherited by the ground loop.

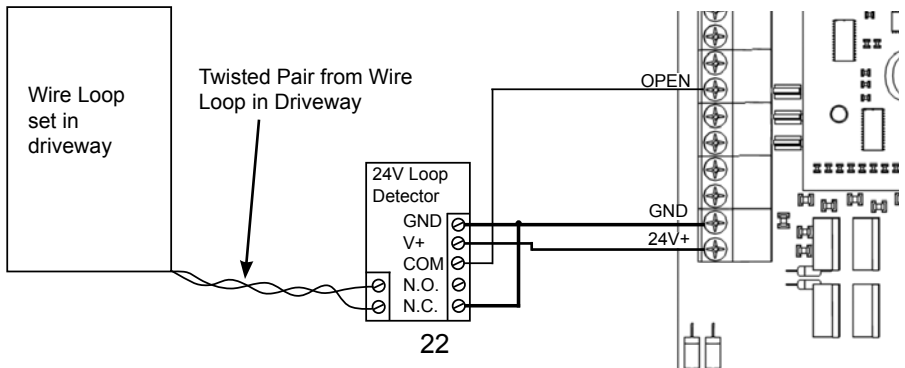

## TERMINATING A 7-DAY TIMER, DIGITAL KEYPAD OR KEYSWITCH TO HOLD THE GATE OPEN.

A 7-Day Timer, Digital Keypad, Key switch or any other clean contact normally closed (NC) device can be used to hold the gate open. Because this is a normally closed connection all devices must be OFF (contact closed) before the gate will close. To hold the gate open any one device must remain ON (contact open). Gate closure will occur once all contacts are closed and the auto-close delay has timed out.

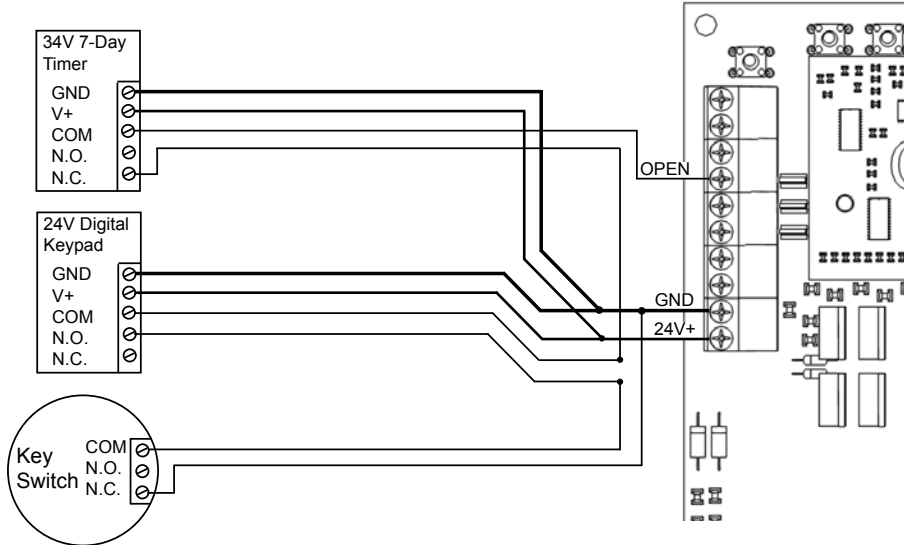

## TERMINATING AN INTERCOM

Intercoms also use a normally open connection to the control board. Intercoms will either have a relay output with clean contacts or provide 12VAC or 12VDC to directly operate an electric strike lock. The later requires a relay, available as an accessory and will work with both 12VAC or 12VDC.

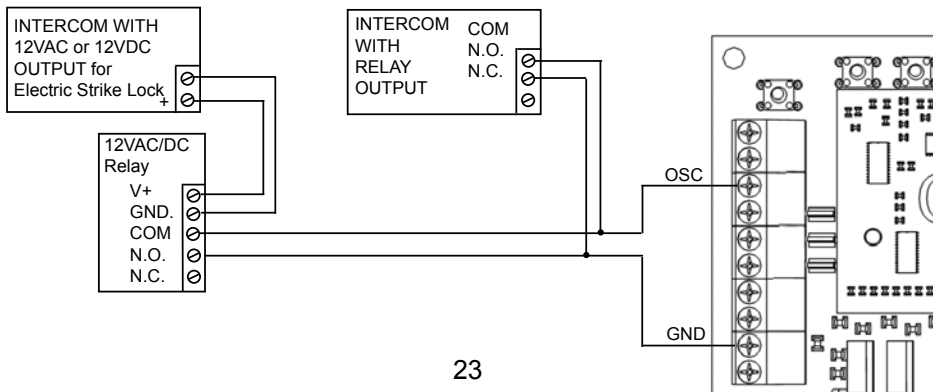

## TERMINATING SEPERATE OPEN, STOP AND CLOSE P/Bs

With some Industrial Applications it may be necessary to have three separate Press Buttons for Opening, Stopping and Closing the Gate.

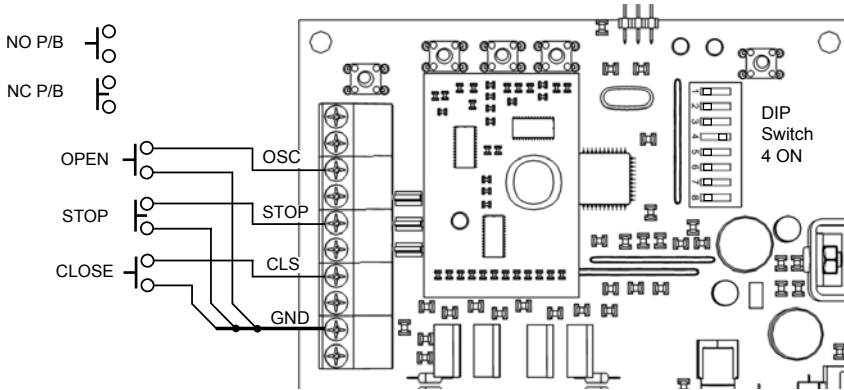

## TERMINATING EMERGENCY STOP DEVICES

For Industrial gates exposed to the general pedestrian traffic it is a good idea to install emergency stop photocells in area's or possible entrapment or an emergency stop press button for staff.

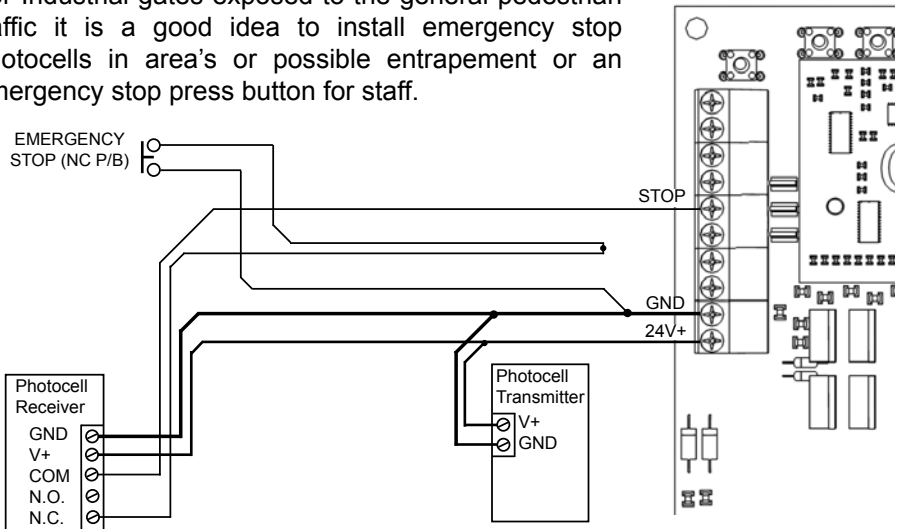

## POWERING UP FOR THE FIRST TIME

Before you can go any further you must Power the Gate operator up for the first time. **Make sure the control board input shunts are ON.** Then plug the Batt/ DC IN terminal in.

## STEP 5 - TUNE THE REMOTE CONTROLS IN

If an on board receiver is used (not a stand alone receiver)

Button A is the main button on the remote control for opening the gate. The other buttons can be used for other options or opening a garage door (e-Gate RX-1 receiver required).



**Each remote control transmits a unique digital code.** Before the control board can respond, it must first **learn this code and know what action to take.**

### REMOTE CONTROL WITH OPEN, STOP AND MANUAL CLOSE

At the top right hand corner of the Control Board are three press buttons used for Learning the remote controls codes for different actions.

**For Opening the gate with Manual Stop and Close** Press the “OSC” Learn Button, a beeper will start beeping, then press a button on the remote control within range of the gate and the beeper will beep more

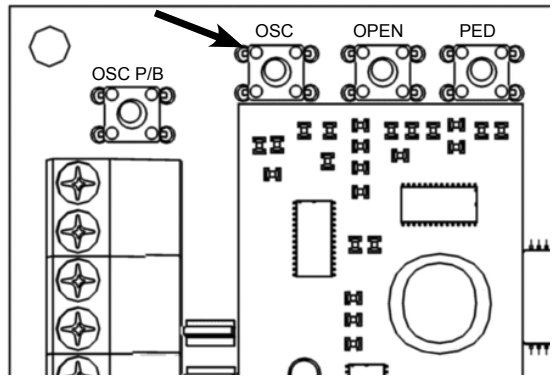

rapidly for a second to confirm it has been learned. This button should now operate the gate. Repeat the same with all remote controls.

### REMOTE CONTROL OPEN WITH AUTO-CLOSE.

If you do as above but use the “OPEN” Learn Button, the remote control will now open the gate only and it will close automatically after auto-close delay or close with an OSC or CLOSE input.

You can use one remote control button to open the gate with manual close (OSC) and a second with auto-close (OPEN) if you like. Button A is handy to have with open only and auto-close for normal use and button B with Open, Stop and Manual close in case you want to back a trailer in and don't want the gate closing on you.

The control board can Learn up to 60 separate remote control buttons.

## **REMOVING REMOTE CONTROLS**

To remove one remote control button press the OSC LEARN button, a beeper will start beeping, then press the already learned remote control button you wish to remove, the beeper will beep more rapidly for a second to confirm removal.

If you don't have the remote control then you must remove all remote controls and re-Learn the ones you have. If you have a lot of remote controls then consider using the RX-Mega stand alone receiver as it can learn up to 1000 remote controls and individual remote controls can be removed even if it has been lost.

To remove all remote controls press and hold OSC LEARN button for more than 10 seconds (beeps) and the beeper will beep more rapidly indicating that all remote controls have all been removed.

## **REMOTE CONTROLLED PEDESTRIAN ENTRY**

If your automatic gate is the only way in or out of your property you can allow user access on foot only, by having the remote control open the gate part way and closing automatically after a pre-set delay. This delay can be set independently from the vehicular entry auto-close delay see "Changing the Pedestrian-close Delay" section in step 9.

Use the "PED" Learn Button on the control board and any unused button on the remote control as you did above. To set the amount the gate will open see Step 7.

## **USER ADDING REMOTE CONTROLS AT LATER DATE**

If you have at least one remote control that operates your gate you can use this to tune in new remote controls without having to open the control box up. This is done by pressing combinations of buttons together on the working remote control within range of the gate. Pressing Buttons A and D together is the same as pressing the "OSC" Learn Button on the control board, A and C together is the same as pressing the "OPEN" Learn button and B and D for "PED" Learn Button. Once you press any of these combinations you'll hear the beeper in the control box beeping. You can now press a button on a new remote control to get it to operate the gate.

Remote control buttons can also be deleted from memory this way. As a safe guard not all remote control buttons can be deleted, using this method, there will always be one left working, so the end user can't accidentally delete them all and not know how to get it working again.

## STEP 6 - LEARN GATE OPEN AND CLOSE LIMITS

Top RH corner of control board

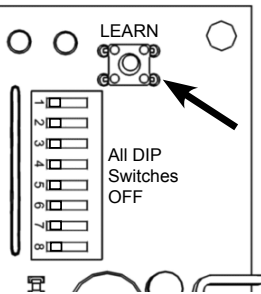

**THE GATE OPEN AND CLOSE LIMITS MUST BE LEARNED BEFORE THE OPERATOR WILL WORK PROPERLY.** The control board has a special function for Learning the Gate Limits automatically.

**IF YOU WISH TO USE THE PEDESTRIAN ENTRY FEATURE** then start by opening the gate by the desired amount using the OSC P/B on the control board, other wise any position will do.

Top LH corner of control board

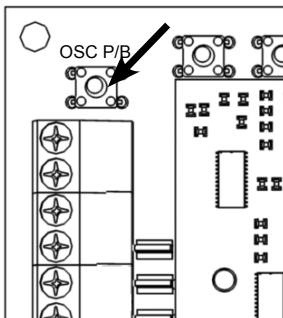

**TO START THE LEARN GATE LIMITS FUNCTION** make sure all DIP Switches are OFF then press the LEARN button and the Beeper will start beeping. Now press the OSC P/B on the control board or remote control to start the function running.

**ONCE STARTED** the gate will start closing slowly as it searches for the close stop.

**WHEN IT FINDS THE CLOSE STOP** it will beep rapidly for a second to confirm then start opening to find the open STOP.

**ONCE THE OPEN STOP IS FOUND** the controller will beep rapidly for a second to confirm then go back to normal operation leaving the gate open.

**THE CONTROLLER WILL REMEMBER THE OPEN AND CLOSE LIMITS** from this time on, even if the power is removed from the operator. During normal operation each the gate will always slow down just before the Hard Stop and drive gently against it.

## STEP 7 - ACTIVATE AND TEST ACCESSORIES

Any intercoms, key switches, press buttons or digital keypads connected to the OSC, PED, or CLOSE inputs can now be tested. The OSC input opens, stops and closes the gate. The PED input opens the gate part way, then will close automatically after the Ped-close delay. The CLOSE input closes the gate only.

Any devices connected to the OPEN, STOP or PC inputs require their shunt to be removed before they will be active. The open input opens the gate, will hold it open while ON and will close automatically after auto-close delay once OFF. The STOP input will stop the gate in any direction when ever it is moving. The PC input will reverse the gate while closing only and hold it open while it remains ON and will close automatically after close delay once OFF.

### OTHER OPTIONS FOR CONTROL INPUTS

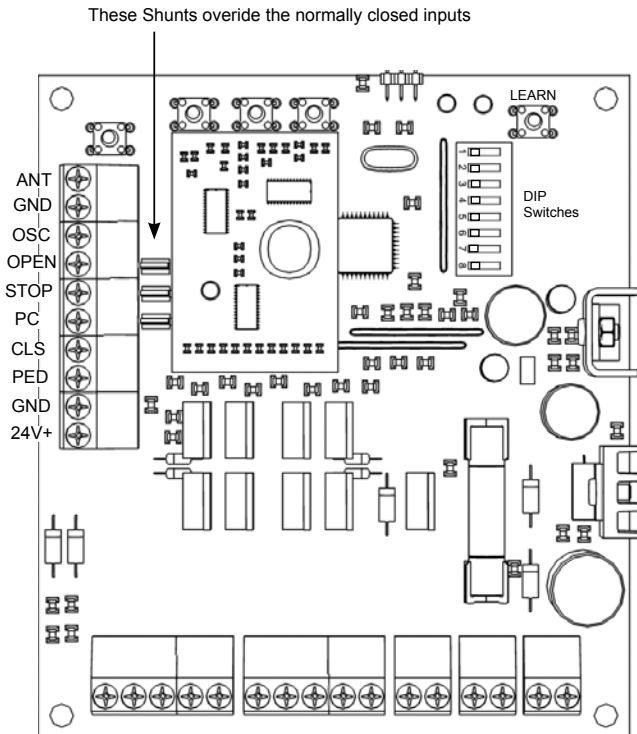

**DIP 1 ON** - activates auto-close function for the OSC control input or any remote control button that has been activated for OSC operation. Gate will close after preset auto-close delay.

**DIP 3 ON** - allows the Photocell(s) to control closing of the gate immediately or after a preset Photocell-close delay - default delay is 2 seconds

**DIP 4 ON** - changes the OSC input so it can open the gate only. Ideal when there is a lot of users. Must be used with auto-close or the Close Control input to close the gate.

**DIP 5 ON** - deactivates the auto-close feature for the OPEN only control input. This can be handy for some commercial installations.

**DIPs 2, 6, 7 and 8** are spare and can be used to select special features that may be programmed into the control board.

## STEP 8 - FINE TUNE GATE OPERATOR PREFERENCES

The DIP Switch and Learn Button have a secondary purpose, which is to make changes to the Control Boards preferences. Once the preferences have been set the DIP switches should be returned back to the way they were for normal operation.

### CHANGING THE AUTO-CLOSE DELAY

Top RH corner of control board

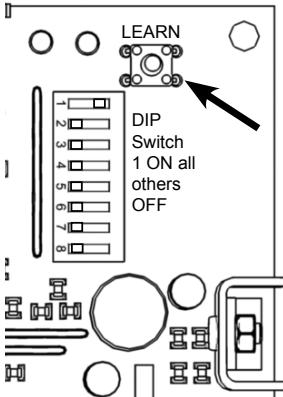

**With DIP Switch 1 only ON, press the LEARN button** and the Beeper will start beeping, it is not necessary to hold the LEARN button. **Now wait for the desired Auto-close time and press the LEARN button again.** The Beeper will beep more rapidly for a second to confirm the new delay has been learned.

The Beeper beeps once a second, so if you count the beeps you are counting seconds, handy if you want an exact time.

If you leave it beeping it will time out after 4 minutes and set this as the auto-close delay.

### CHANGING THE PHOTOCCELL-CLOSE DELAY

Top RH corner of control board

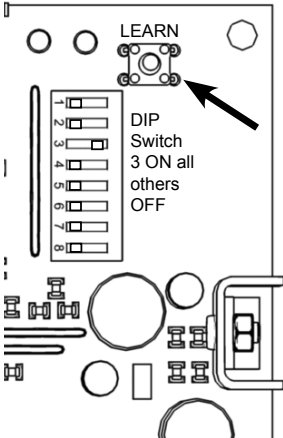

**With DIP Switch 3 only ON, press the LEARN button** and a Beeper will start beeping, it is not necessary to hold the LEARN button. **Now wait for the desired Photocell-close delay and press the Learn button again.** The Beeper will beep more rapidly for a second to confirm the new delay has been learned.

The Beeper beeps once a second, so if you count the beeps you are counting seconds, handy if you want an exact time.

If you leave it beeping it will time out after 4 minutes and set that as the delay.

## CHANGING THE PEDESTRIAN-CLOSE DELAY

Top RH corner of control board

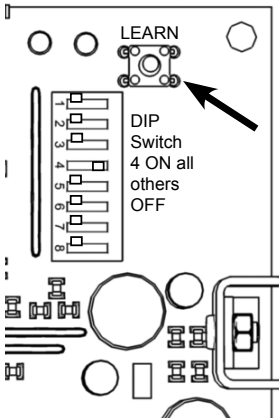

**With DIP Switch 4 only ON, press the LEARN button** and a Beeper will start beeping, it is not necessary to hold the LEARN button. **Now wait for the desired Pedstrian close delay and press the Learn button again.** The Beeper will beep more rapidly for a second to confirm the new delay has been learned.

The Beeper beeps once a second, so if you count the beeps you are counting seconds, handy if you want an exact time.

If you leave it beeping it will time out after 4 minutes and set that as the delay.

## CHANGING THE LOCK/LIGHT OUTPUT

Top RH corner of control board

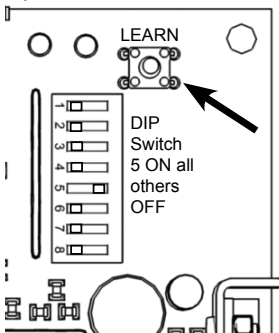

There are 6 modes of operation for the Lock/Light output including:

1. Strike Lock - comes ON for 2 seconds on open
2. Light timer 1 - comes ON for 1 minute on open
3. Light timer 4 - comes ON for 4 minutes on open
4. Open indicator - comes ON when gate is open
5. Brake mode - comes ON when gate is moving
6. Clamp mode - comes ON when gate is closed.

The factory setting for the Lock/Light Output is mode 2 for a light timer of 1 minute.

**With DIP Switch 5 only ON, press the LEARN button** and the control board will beep out the current mode ie. if the mode is 3 there will be 3 beeps, then there will be a pause for 2 seconds and it will start beeping again. This is when you can change the mode by pressing the Learn button at the desired beep ie. if you want to change it to mode 5 then press the Learn button during the 5th Beep. The control board will beep more rapidly to confirm the new setting .

If you change your mind half way through just don't press the Learn button again and it will time out after 6 beeps and no change will be made.

## CHANGING THE LEVEL OF SOFT START AND SOFT STOP

Top RH corner of control board

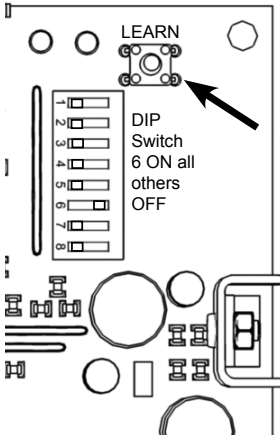

There are 16 levels of Soft Start/Stop numbered from 1 to 16. The factory setting is 8, 1 being least and 16 being the most.

**With DIP Switch 6 only ON, press the LEARN button** and the control board will beep out the current level ie. if the level is 3 there will be 3 beeps, then there will be a pause for 2 seconds and it will start beeping again. This is when you can change the level by pressing the Learn button at the desired beep ie. if you want to change it to level 5 then press the Learn button during the 5th Beep. The control board will beep more rapidly to confirm the new setting.

If you change your mind half way through just don't press the Learn button again and it will time out after 16 beeps and no change will be made.

## CHANGING THE GATE OBSTRUCTION SENSITIVITY

Top RH corner of control board

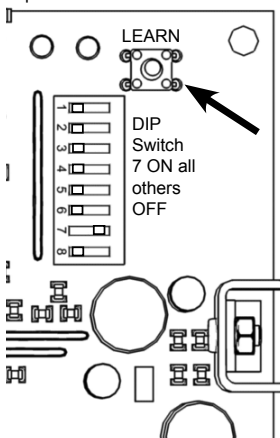

If the gate is obstructed while operating it will stop and reverse away. There are 6 different levels of Obstruction Sensitivity for the gate numbered from 10 to 16. The factory setting is 12 with 10 being the most sensitive and 16 being the least.

**With DIP Switch 7 only ON, press the LEARN button** and the control board will beep out the current level ie. if the level is 12 there will be 12 beeps, then there will be a pause for 2 seconds and it will start beeping again. This is when you can change the level by pressing the Learn button at the desired beep ie. if you want to change it to level 15 then press the Learn button during the 15th Beep. The control board will beep more rapidly to confirm the new setting.

If you change your mind half way through just don't press the Learn button again and it will time out after 16 beeps and no change will be made.

## RETURNING TO THE FACTORY SETTINGS

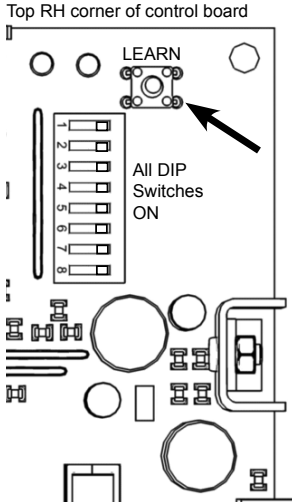

If you get into trouble and want to return everything back to the way it was before you started you can restore the factory settings by turning ALL DIP Switches ON and pressing the LEARN Button. The beeper will beep rapidly for a second to confirm the factory settings have been restored.

This function resets everything including: removing all remote controls and resetting the Gate Open Limit.

You must turn the DIP Switches OFF again before proceeding further.

## **RECOMMENDED MAINTENANCE SCHEDULE**

Maintenance Schedule depends on frequency of use as follows:

Cycles per day	Maintenance Period
Over 150 . . . . .	each Month
100 to 150 . . . . .	every 2 months
50 to 100 . . . . .	every 4 months
20 to 50 . . . . .	every 6 months
up to 20 . . . . .	every 12 months

## **MAINTENANCE CHECKLIST**

Use the following Checklist for Scheduled Maintenance of the SWG-24V-IND-S Gate Operator

- Gate Hinges in Good Condition and Lubricated
- Gate Swings Freely with suitable clearance from ground/posts.
- Gate Hard Stops in good condition
- Gate Operator and gate mounting bracket bolts/nuts are tight
- All arm joints loose but firm
- No oil leaks from gear boxes
- Gear box drive cogs tight on shafts
- Gear box mounting bolts/nuts tight
- Manual release/torque limiter works correctly
- Inside operator clean from insects, animal droppings, spider webs etc...
- 'Baygon' Surface spray around operator (not on electronics)
- Chain lightly oiled
- All Electrical Connections tight
- Limit Switches (if used) operate in appropriate open and close positions
- Access/Exit control devices work properly
- External Safety devices work properly
- External Locks work properly
- Check all components for corrosion



## ACCESSORIES

TX-4	Extra Remote Controls for either 433.92Mhz (Blue) or 315Mhz (White)
RX-1	Stand alone Receiver - to allow a garage door or another brand of gate operator to be operated with the e-Gate remote control ether 433.92Mhz or 315Mhz.
RX-Mega	Stand alone receiver for a large number of users allows use of up to 1000 remote controls. A remote control can be deleted even if lost.
ANT-1	Antenna for remote control ether 433.92Mhz or 315Mhz.
Batt-TX	Replacement Battery for TX-4 Remote control
Batt-12V-7Ah	Replacement Battery for Sliding Gate operator (2 required for 24V)
Batt-12V-26Ah	Battery for extending continous operating time (2 required for 24V)
Batt-12V-65Ah	Battery for extending continous operating time (2 required for 24V)
ST-130	Wired Single Channel Digital Keypad
VCB-12	Voltage Converter Board 16 to 24VAC/DC in and 12V 500mA out
RLY-12	Relay Board 12VAC/DC in and clean contacts rated at 60VDC/125AC 2A
RLY-24	Relay Board 24VAC/DC in and clean contacts rated at 60VDC/125AC 2A
PC-1	Photocell 12/24VAC/DC 15m outdoor

## TROUBLE SHOOTING

Gate runs in the wrong direction - check the motor power wires are correct, if wired the wrong way around the motor will travel in the wrong direction.

Gate runs for a short distance then stops - check the gate obstruction sensitivity or operator isn't being overloaded by a stiff gate.

Operator not working at all - check power cord or battery cable is plugged in. Check there is power at the gate. Check fuse on the control board. Check input shunts are correct or control accessories are working properly.

Operator running slowly - check the battery is connected properly and charged. A fully charged battery should be at 27.6VDC. Anything lower than 24VDC may be too flat to operate properly.

Gate won't work when first powered up - check the OPEN, STOP and PC input cable connections and shunts are correct and all accessories that may be connected are working properly.

OPEN, PC or STOP inputs won't work - check the shunts for these inputs have been removed. These shunts override the inputs preventing them from working.

Remote control range drops some times - most likely caused by interference from some other device in the area using a similar frequency. Installing an external antenna can minimize the effects of interference, other wise if this doesn't help the frequency of the remote controls can be changed. Each remote control will need to be changed for a different frequency along with the receiver module plugged into the e-Gate control, stand alone receiver board(s) or antenna's. The receiver module is a small yellow board that plugs into the main board near where the antenna is wired in. Power should be removed from the operator before a receiver module is changed. The remote controls, receivers and Antennas all come in either 433.92Mhz or 315Mhz.

## **WARRANTY**

a 12 Month Back to Base Warranty is offered by Grant's Automation for any defect in a Gate Operator System manufactured by Grant's Automation or any third party component supplier to Grant's Automation due to faulty workmanship or materials causing the Operator to fail to work as specified in this Installation and Service Manual.

Should any fault occur during the first 12 months after the operator was purchased, it should be returned to the factory for repair or at the discretion of Grant's Automation replacement at no charge under the following conditions:

1. Proof of purchase is required ie. Invoice or purchase details recorded by Grant's Automation.
2. If an operator is not installed immediately after purchase, at the discretion of Grant's Automation, the warranty may be extended to up to a maximum of 12 months after the date installed.
3. The operator has been installed and serviced according to this Installation and Service Manual.
4. The operator has not been used for a gate larger, of a different type or higher frequency of use than that specified in this Installation and Service Manual. The gate specifications are required before any claims will be accepted.
5. The operator hasn't been used in a highly corrosive environment or has been exposed to contaminants that could cause the operator to fail.
6. The operator has not been used for purposes other than it was intended for.
7. The operator has not been tampered with or modified by any party not authorised in writing by Grant's Automation to do so.
8. The operator has not been damaged by any malicious act, accident, animals or adverse weather conditions beyond the control of Grant's Automation.
9. A reasonable amount of care with handling or using the operator has been taken.